

8 7 6 5 4 3 2 1

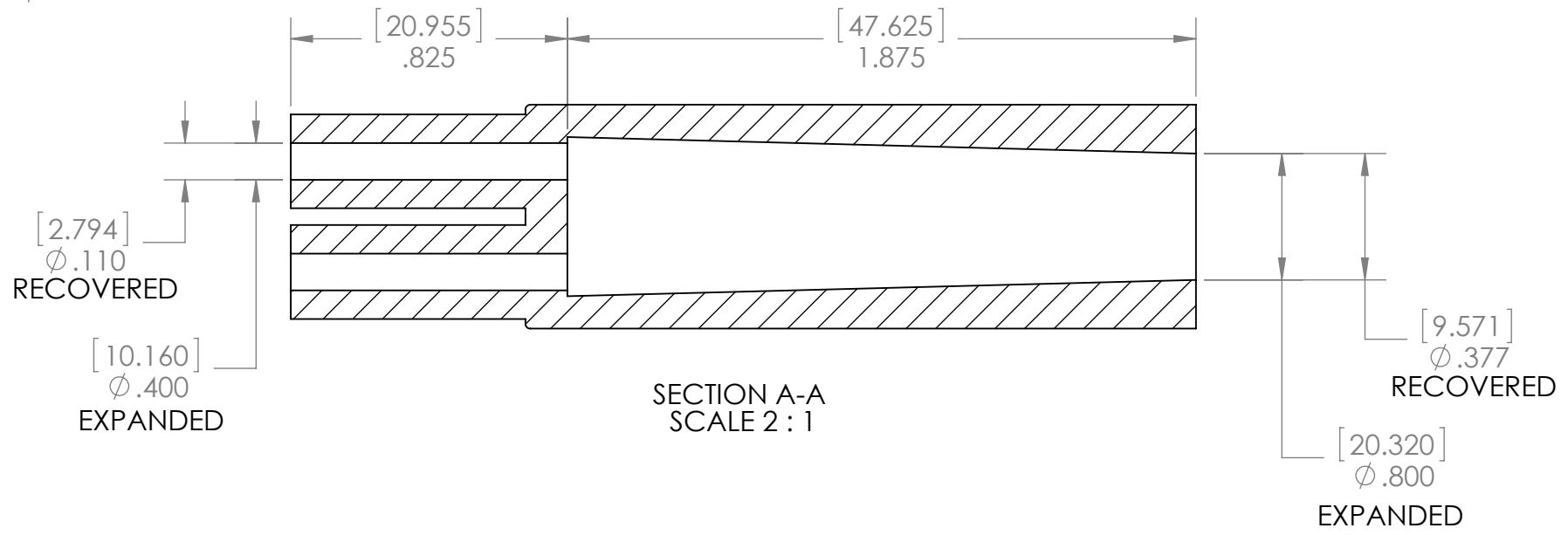
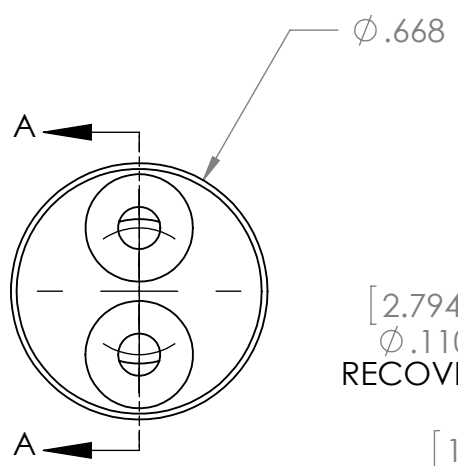
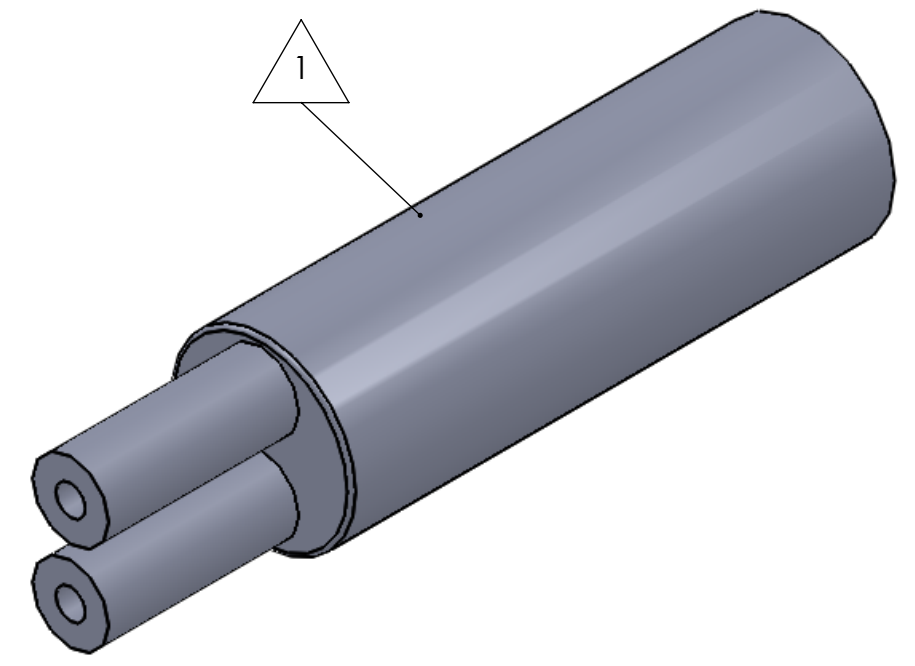

ITEM	PART DESCRIPTION	PART NO.	MATERIAL	<b>Nu-Tech</b>	
	Heat-shrinkable boot		HS 3123		
				UNLESS OTHERWISE SPECIFIED: DIMENSIONS ARE IN INCHES TOLERANCES: FRACTIONAL $\pm 1/32$ THREE PLACE DECIMAL $\pm 0.030$	
				DWG. NO.	
	Adhesive	A-010	Hotmelt ADH	WEIGHT: 0.028	REV
				DRAWN: HH	DATE: 9/29/2016
				SCALE: 1:1	SHEET 1 OF 1

8 7 6 5 4 3 2 1