

8 7 6 5 4 3 2 1

D
C
B
A

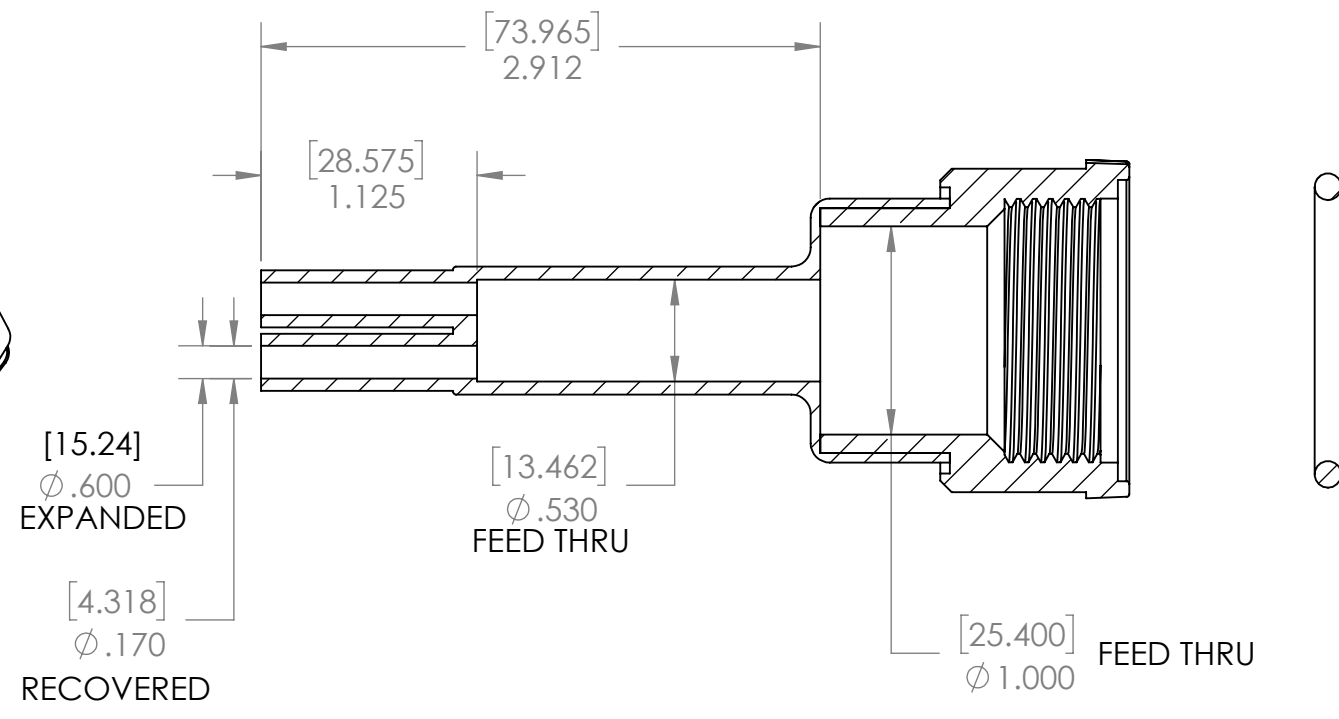

SECTION A-A
SCALE 1 : 1

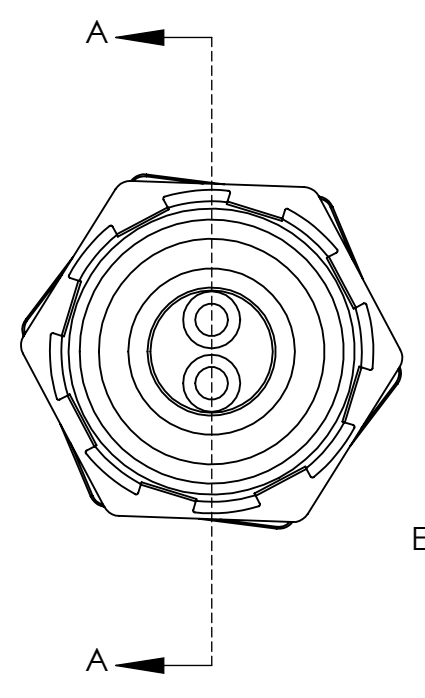
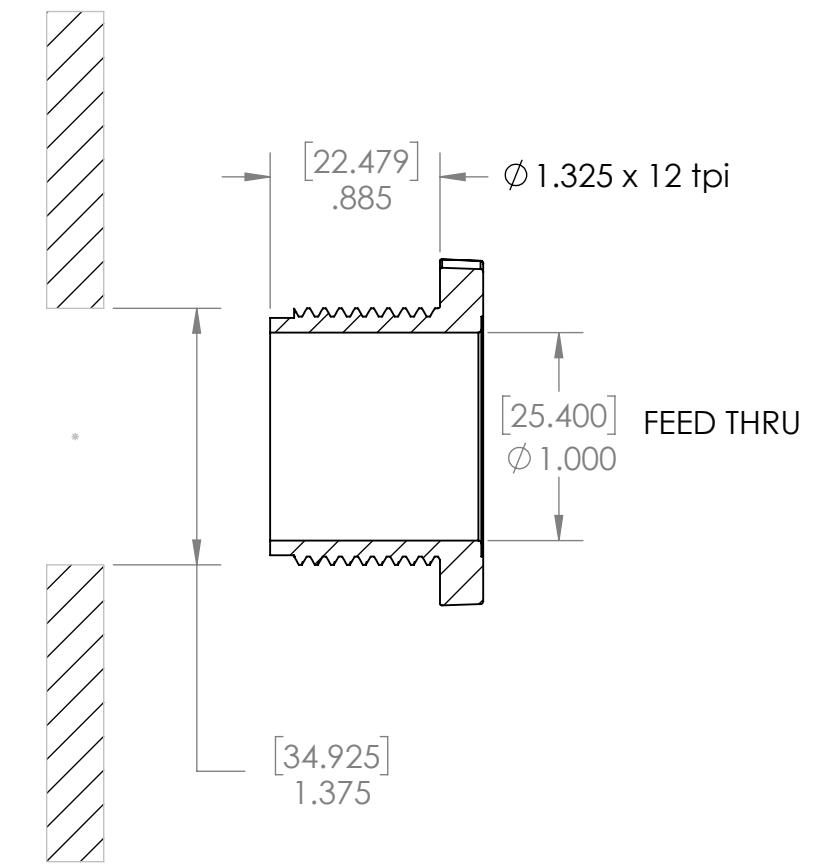
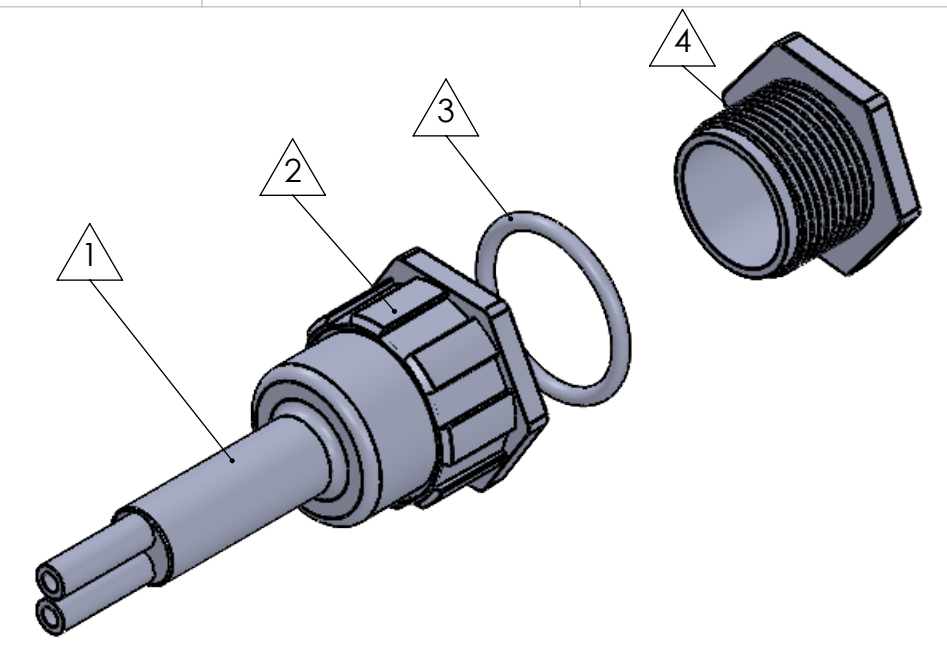

ITEM	PART DESCRIPTION	PART NO.	MATERIAL	Nu-Tech	
①	Heat-shrinkable boot		HS 3123		
②	Body		Nylon	PART NO. 3-NUS-2B	
③	O-ring		Buna	DWG. NO. PRP:"SW-Title"	
④	Nut		Nylon	WEIGHT: SW-Mass@par19.SLDPRT REV	
⑤	Adhesive	A-010	Hotmelt ADH	DO NOT SCALE DRAWING	
⑥				DRAWN: HH	DATE: 5/20/2021
				SCALE: 1:2	SHEET 1 OF 1

8 7 6 5 4 3 2 1