

8 7 6 5 4 3 2 1

D
C
B
A

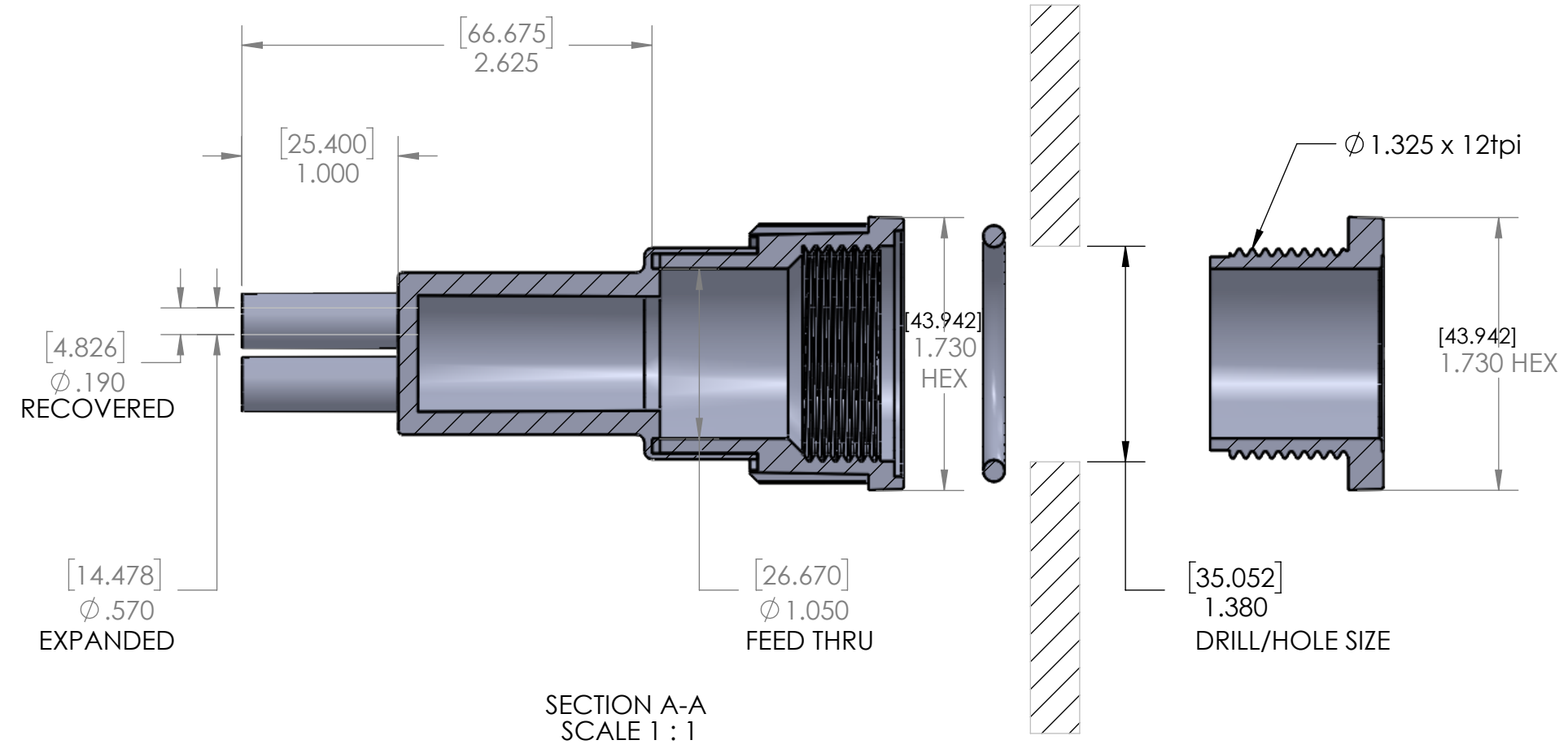
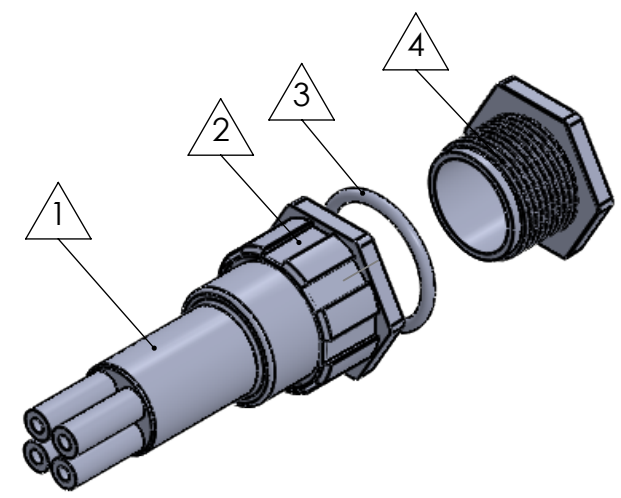
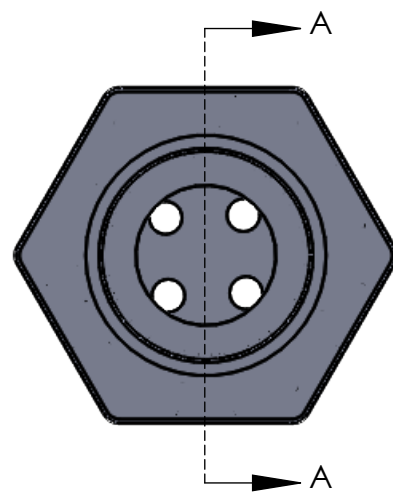

SECTION A-A
SCALE 1 : 1

ITEM	PART DESCRIPTION	PART NO.	MATERIAL
①	Heat-shrinkable boot	NUBB4-2	HS 3123
②	Body	S-3B	Nylon
③	O-ring	S-3OR	Buna
④	Nut	S-3N	Nylon
⑤	Adhesive	A-010	Hotmelt ADH
⑥			

Nu-Tech

UNLESS OTHERWISE SPECIFIED:
DIMENSIONS ARE IN INCHES
TOLERANCES:
FRACTIONAL ±1/32
THREE PLACE DECIMAL ± 0.030

PART NO.
3-NUS-4B

DWG. NO. PRP:"SW-Title"

WEIGHT: SW-Mass@par19.SLDPRT REV

DO NOT SCALE DRAWING

By: Keven

DATE: 5/28/2021

SCALE: 1:2

SHEET 1 OF 1

8 7 6 5 4 3 2 1