

8 7 6 5 4 3 2 1

D  
C  
B  
A

D  
C  
B  
A

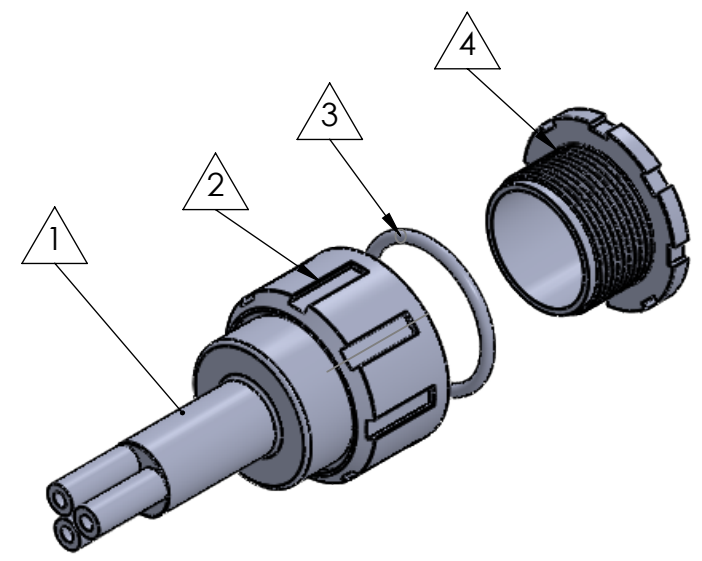
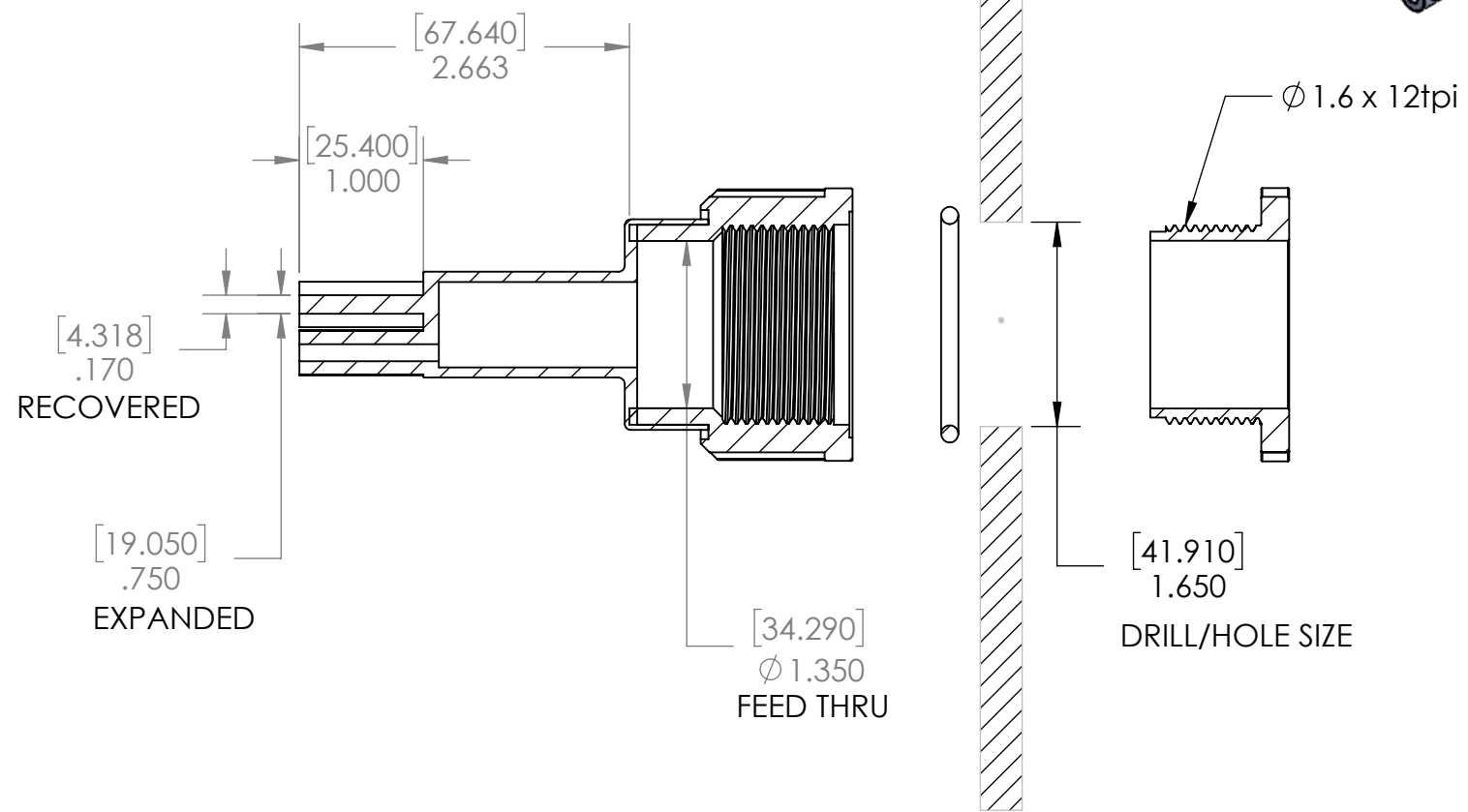
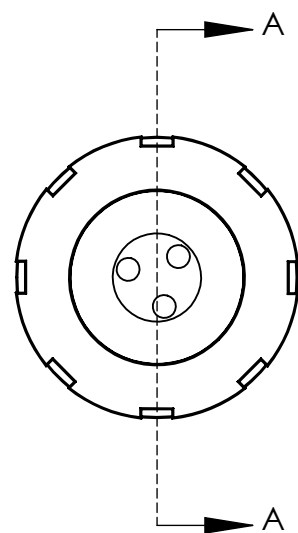

ITEM	PART DESCRIPTION	PART NO.	MATERIAL
①	Heat-shrinkable boot	NUBB3-2	HS 3123
②	Body	S-3XB	Nylon
③	O-ring	S-3XOR	Buna
④	Nut	S-3XN	Nylon
⑤	Adhesive	A-010	Hotmelt ADH
⑥			

**Nu-Tech**

UNLESS OTHERWISE SPECIFIED:  
 DIMENSIONS ARE IN INCHES  
 TOLERANCES:  
 FRACTIONAL  $\pm 1/32$   
 THREE PLACE DECIMAL  $\pm 0.030$   
 DO NOT SCALE DRAWING  
 By: Keven

PART NO.	3X-NUS-3B	
DWG. NO.	PRP:"SW-Title"	
WEIGHT:	SW-Mass@par19.SLDPRT	REV
DATE:	5/28/2021	SCALE: 1:2
		SHEET 1 OF 1

8 7 6 5 4 3 2 1