

8 7 6 5 4 3 2 1

D
C
B
A

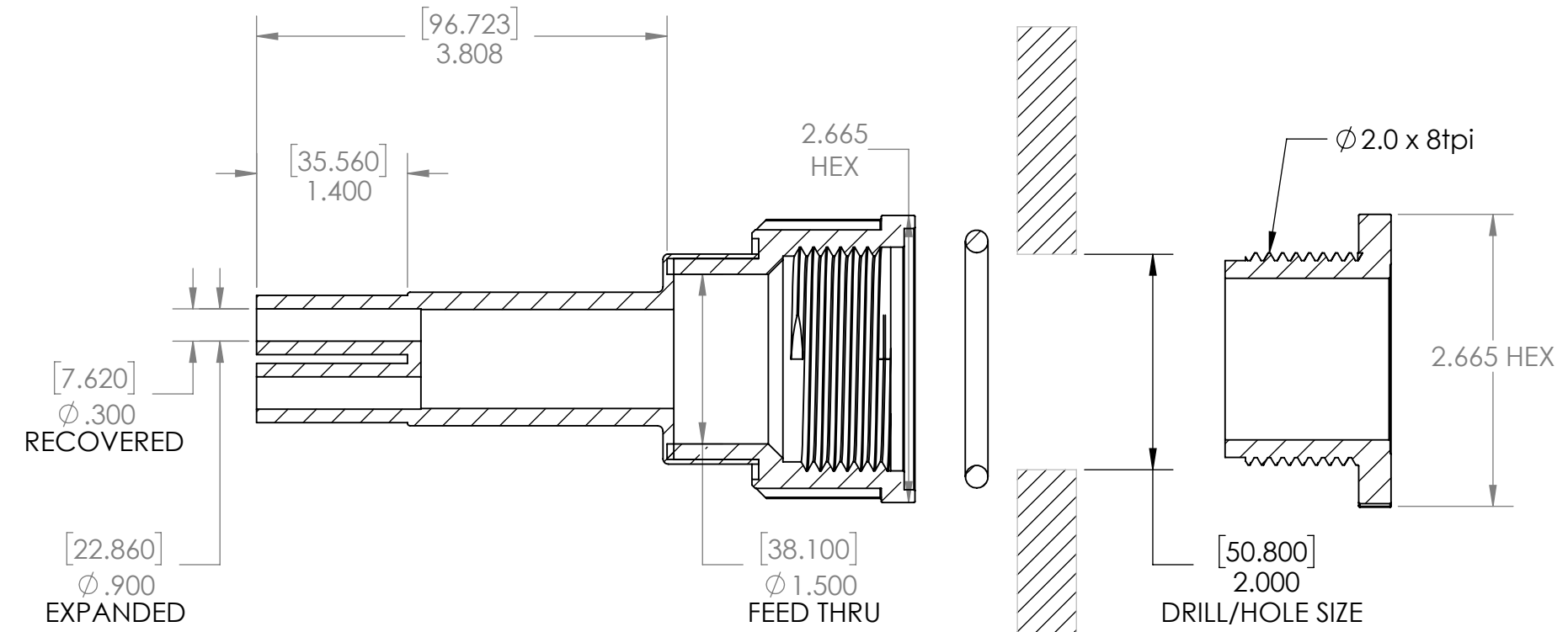

SECTION A-A
SCALE 1 : 1.5

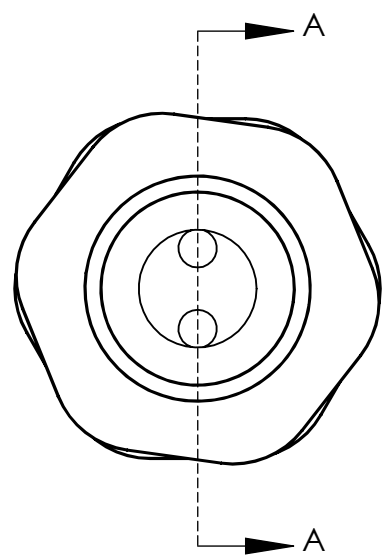
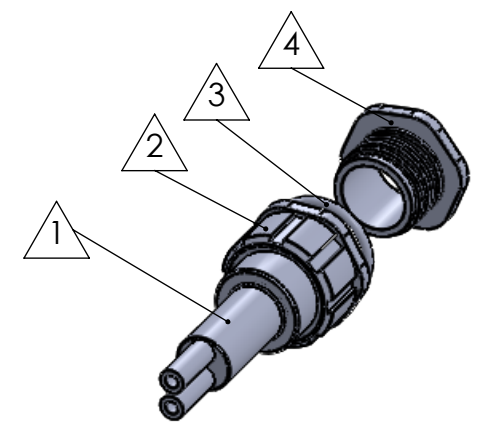

ITEM	PART DESCRIPTION	PART NO.	MATERIAL
①	Heat-shrinkable boot	NUBB2-3	HS 3123
②	Body	S-4B	Nylon
③	O-ring	S-4OR	Buna
④	Nut	S-4N	Nylon
⑤	Adhesive	A-010	Hotmelt ADH
⑥			

Nu-Tech

UNLESS OTHERWISE SPECIFIED:
 DIMENSIONS ARE IN INCHES
 TOLERANCES:
 FRACTIONAL ± 1/32
 THREE PLACE DECIMAL ± 0.030

DO NOT SCALE DRAWING

By: Keven DATE: 5/28/2021

PART NO. 4-NUS-2C	
DWG. NO. PRP:"SW-Title"	
WEIGHT: SW-Mass@par19.SLDPRT	REV
SCALE: 1:4	SHEET 1 OF 1

8 7 6 5 4 3 2 1